

# Vetralla 1650 VE2-N-SW-NO / VE2M-N-SM-NO

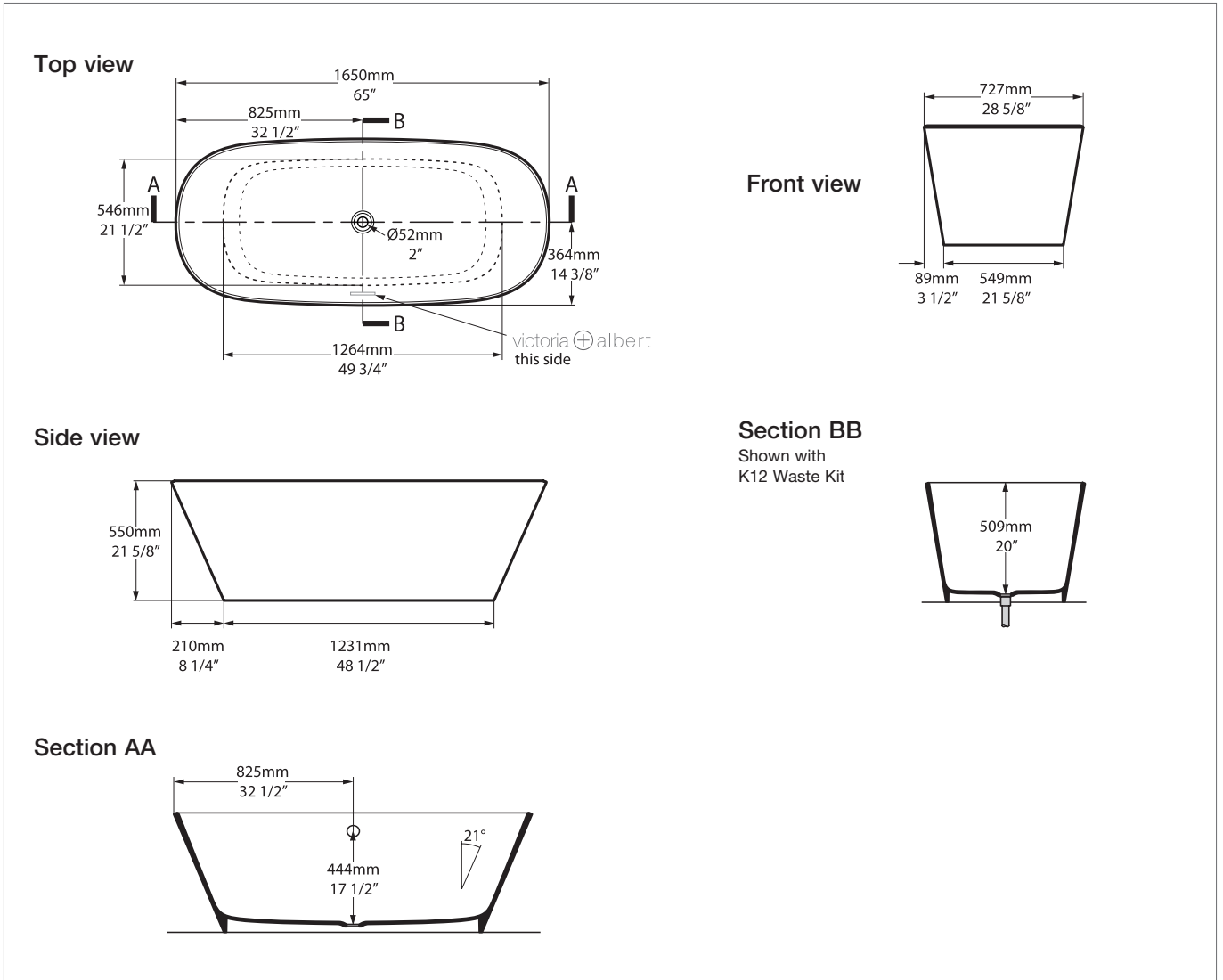

 rich in Volcanic Limestone™

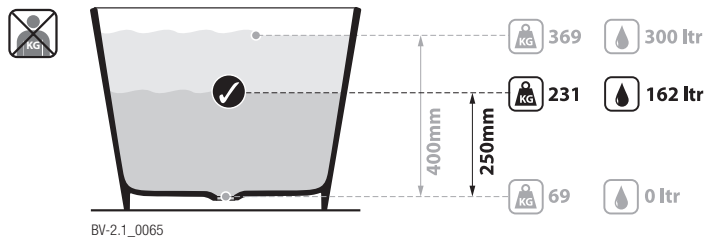

Recommended wastes: K12

\*All measurements subject to +/-5% tolerance  
\*Overflow hole not drilled

 Massachusetts Code: Approved  
cUPC listing by IAPMO: File No. 6574



**25**  
years

Guaranteed for residential use for 25 years\*  
25 Jahre Garantie bei privater Nutzung  
25 ans de garantie pour un usage domestique  
Garantía de 25 años para uso domestico  
La sicurezza garantita per uso residenziale per 25 anni

**8**  
years

Guaranteed for commercial use for 8 years\*  
8 Jahre Garantie bei gewerblicher Nutzung  
8 ans de garantie pour un usage commercial  
Garantía de 8 años para uso comercial  
La sicurezza garantita per uso commerciale per 8 anni

- \* QUARRYCAST™ white products only. Paint finish exterior guaranteed for 2 years.
- \* Nur auf weisse QUARRYCAST™ Produkte. Auf Aussenlackierung gibt es 2 Jahre Garantie.
- \* Uniquement pour les produits en QUARRYCAST™ blanc. Pour les finitions extérieures peintes la garantie est de 2 ans.
- \* Solo sobre productos en QUARRYCAST™ blanco. Acabados de pintura exterior tienen una garantía de 2 años.
- \* Solo per prodotti bianchi in QUARRYCAST™. Finitura esteriore dipinta garantita per due anni.